

This drawing is the sole property of Miether Bearing Products and contains confidential and proprietary information. It is being provided to you for your use and may not be disclosed to any third party or used for any other purpose without Miether's prior written consent. The [materials] must be returned to the Company upon its demand. Your acceptance of these materials constitutes your acceptance of the foregoing terms.

C-35189

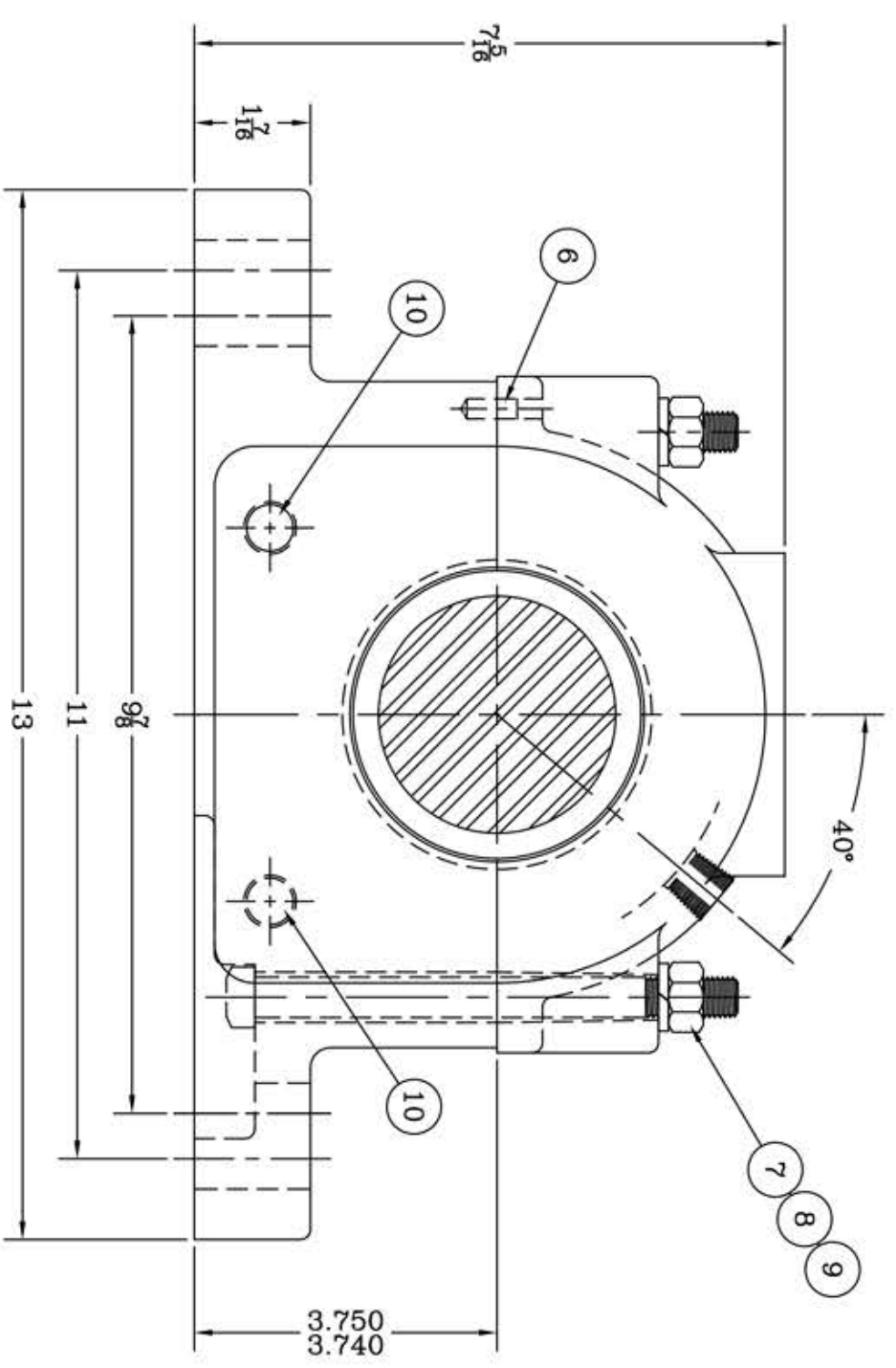

ITEM	DESCRIPTION	DETAIL	REQUIRED
1	HOUSING FSAFD 517 02-15	C-	1 1
2	SPHERICAL ROLLER BEARING	22217K/W-33	1 1
3	STABILIZING RING SR-17-14	A-10600	1 0
4	ADAPTER SNW-17 02-15	B-24410	1 1
5	TRIPLE SEAL RING LER-53	A-10985	2 2
6	DOWEL	$\phi 1/4$ x $3/8$ LONG	2 2
7	CAP BOLT SQUARE HEAD Gr.5	$1/2$ -13 NC x 6" LONG	4 4
8	CAP BOLT HEX. NUT	$1/2$ -13 NC	4 4
9	LOCKWASHER	$1/2$ SPLT MED.	4 4
10	PIPE PLUG	$3/8$ -18 NPT	3 3

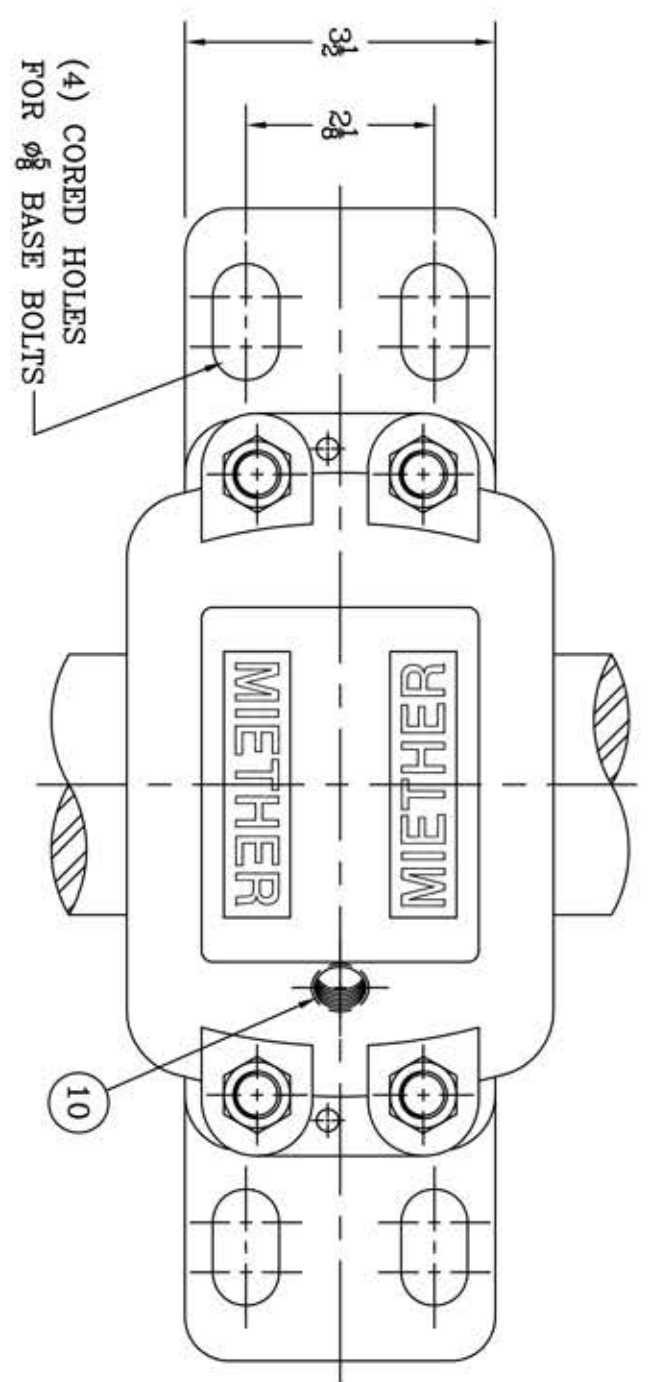
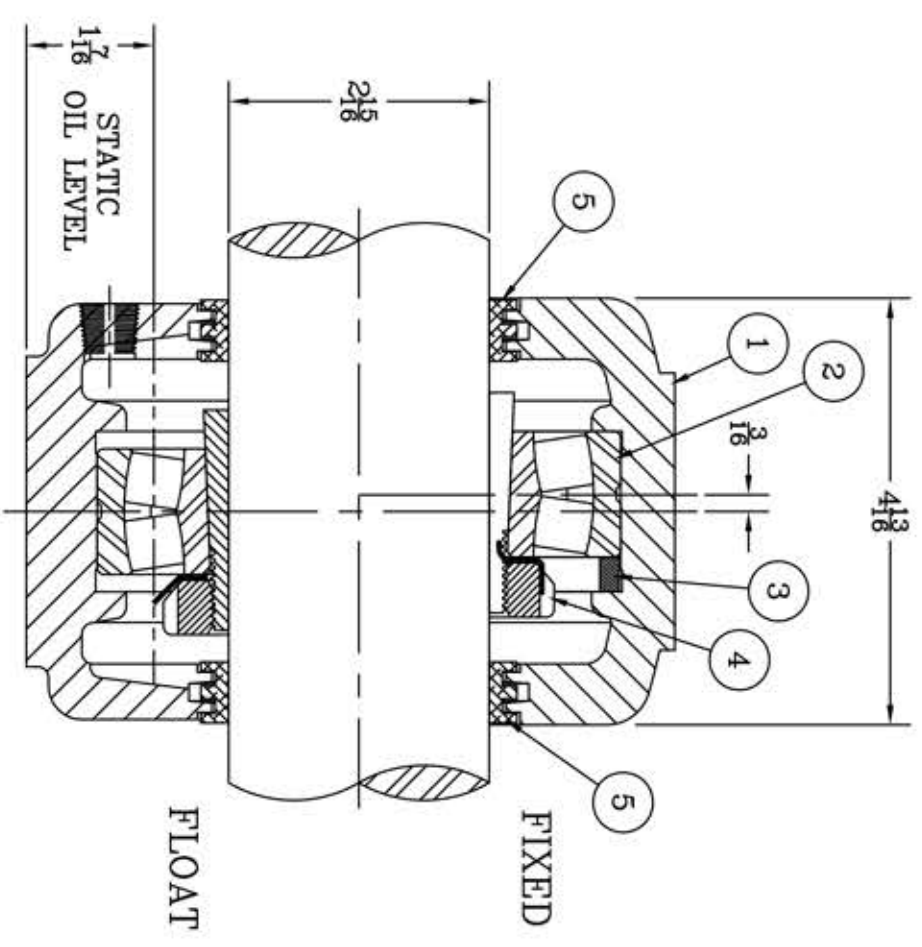

REVISIONS

SYMBOL	DESCRIPTION
$\nabla$	16
$\nabla$	32
$\nabla$	63
$\nabla$	125
$\nabla$	250
$\nabla$	500
$\nabla$	1000

TOLERANCE: UNLESS OTHERWISE SPECIFIED  
 FRACTIONS  $\pm 1/32$ " ANGLES  $\pm 0^\circ 30'$   
 DECIMALS  $\pm .005$  WELD  $\pm 1/16$ "  
 CASTING  $\pm 1/16$ "

A.I.S.I. STANDARD FINISHES

AN ALCO INDUSTRIES COMPANY  
 BEARING PRODUCTS  
 ODESSA, TX. USA

FSAFD 22517 02-15  
 ASSEMBLY DAWING

SCALE 1 = 1.5 ASSEMBLY NO.  
 DRAWN PCF  
 DATE 11/9/12 DRAWING NO. C-35189  
 CHK: